



## RFM Series Field Termination and I.S. Barrier Modules

The RFM family partners PSM's ICT intelligent level transmitter to provide both simple multi-drop network connections and full compliance with ATEX Intrinsic Safety standards where required. RFM is offered with various configurations from a simple termination box to a field mounted Modbus converter that also allows conventional 4-20mA transmitters to be connected to the same Multi-drop data bus.

### The Range

The entire range is offered in a lightweight IP67 aluminium enclosure or a rugged IP67 steel enclosure suitable for harsh environments or open deck mounting

**RFM-1 – Standard Termination Module**

**RFM-2 – As RFM-1 but adds an integral voltage booster and 4-20mA to RS485 Modbus converter**

**RFM-IS – combined Power and RS485 communications I.S. Barrier for use in hazardous area applications —safe area mounted**

**RFM-ISR – As RFM-IS but adds a further module which allows an unregulated power supply to be used and restricts the voltage into the hazardous area to allow higher current levels**

RFM-1 provides a convenient termination point for the ICT sensor cable, connections for input power and digital signal cabling, and "pass-through" connections to feed the power and signal cable to the next RFM. The digital multi-drop communication of the ICT means that the user can link multiple RFM units using a simple 4 core connection dramatically saving on the cable required compared to conventional 4-20mA loops. RFM-1 and it's connected ICT can be mounted in the hazardous area in Intrinsically safe applications when used with a RFM-IS or RFM-ISR barrier.



RFM-2 provides an interface and termination point for "conventional" 4-20mA transmitters and converts the signal to Modbus data. The data can then be sent to the control Computer via the RS485 data bus. Certain measurement technologies (for example Radar level) have a higher power requirement. To allow for this, RFM-2 also provides a local "Voltage Booster". RFM-2 can also be mounted in the hazardous area in Intrinsically safe applications if powered from an RFM-IS or RFM-ISR barrier.

### Hazardous area applications

The function of a Safety barrier is to limit to safe levels, the amount of energy that can pass into the hazardous area.

RFM-IS is located in the Safe Area, and provides Zener Barrier protection for both power and communication lines to hazardous area equipment.

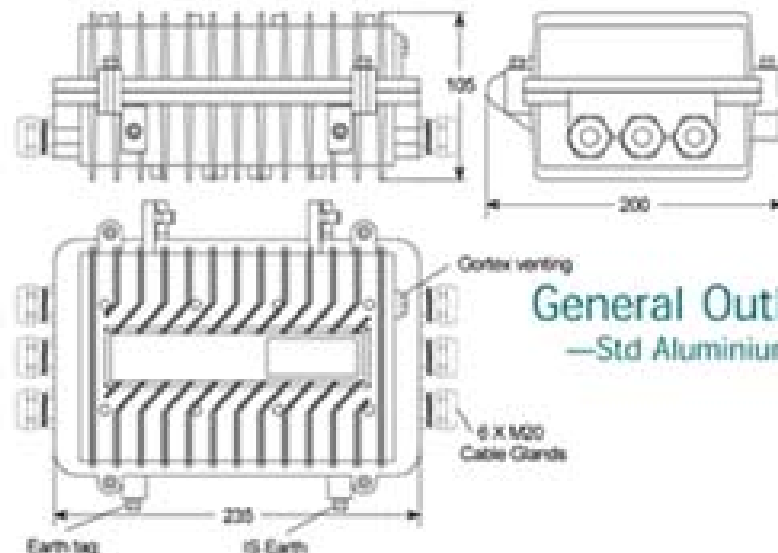

### Benefits at a glance

Significantly reduces cabling required and time to install

Simple low cost I.S. compliance.

One Safety Barrier for multiple Instruments incorporating power and RS485 protection

Full remote access to equipment for fast commissioning

RFM-IS is used where a regulated power supply is available in the safe area. A specific RFM-IS variant will be selected based on the actual supply which can be in the range 18 To 30V DC.

Where ICT's in the hazardous area are being used in analogue (4-20mA) mode, they may also use digital mode communication but only one device can be connected per RFM-IS.

Where ICT's are used in digital only mode, their power requirement is greatly reduced, and multiple units can then be protected using a single RFM-IS.

RFM-IS may also be used to protect conventional 4-20mA transmitters, again by using an RFM-IS for each instrument.

RFM-ISR by adding an onboard regulator and active hazardous area power management any power supply between 15 to 35V DC can be used and RFM-ISR will protect up to 127 ICT's running in digital mode and terminated using the RFM.

RFM-ISR will also provide I.S. protection for conventional instruments connected via RFM-2. The increased power requirements of 4-20mA loops mean that up to 2 RFM2 units and up to 6 digital mode ICT's can be protected by each RFM-ISR Barrier module.

Refer to the back page for typical loop schematics and available combinations/limits.

General Outline  
—Std Aluminium Enclosure



# Specification

IP Rating 67  
 Material : Coated cast Aluminium or galvanised Steel with SIL seal material  
 Cable Entry: 6 x M20  
 Venting : Gortex



for level  
 Intelligent instrumentation



## Typical loop schematics

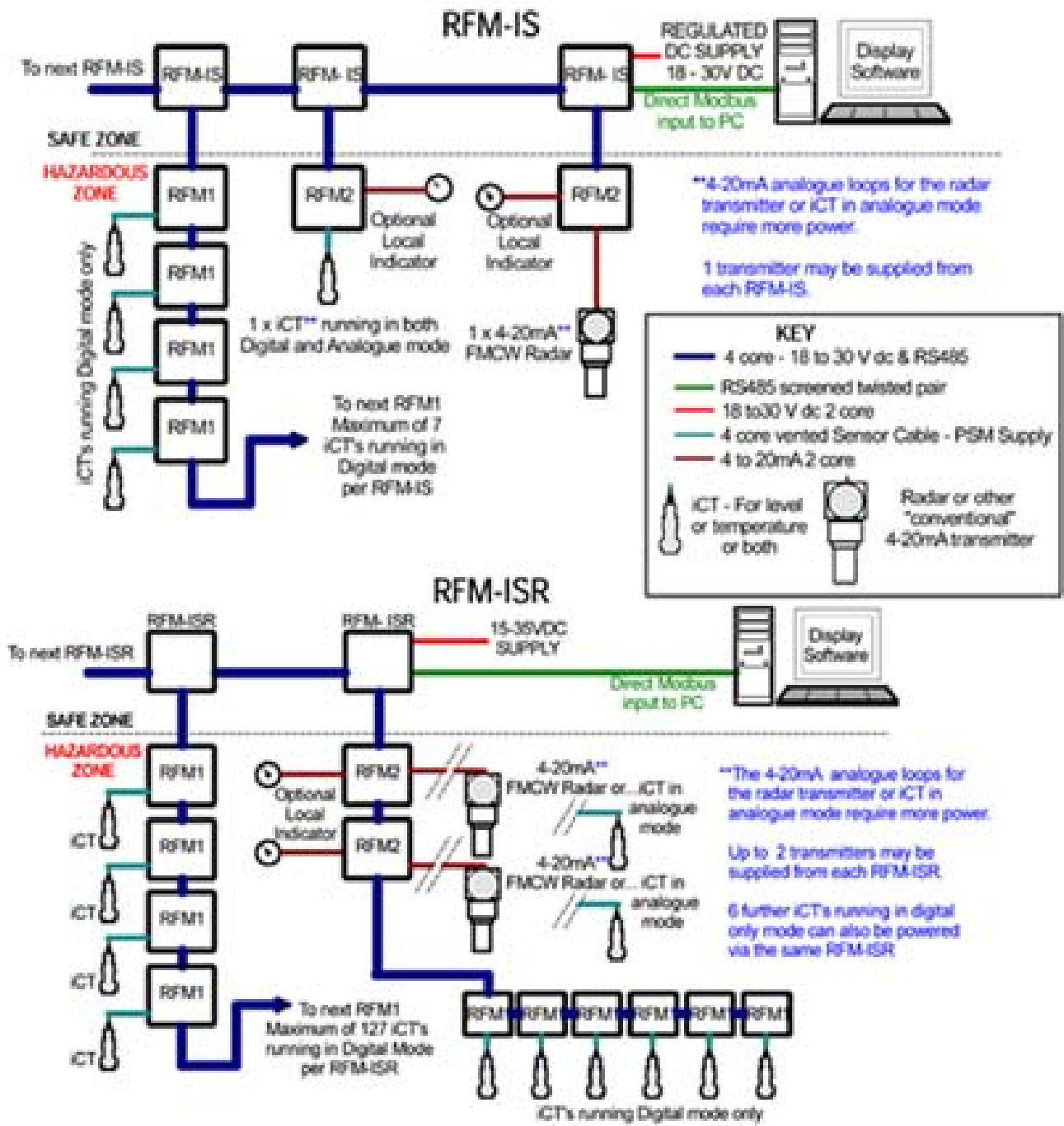

North American Sensors Corp.  
 23400 Hwy. 435  
 Abita Springs, LA 70420



Ph.(985) 893-0909  
 Fax (985)893-0807  
 email: sales@mepinc.net